



Parallel Advanced Technology  
Attachment and Compact  
Flash Micro Channel  
Architecture Bus Interface  
Adapter User Manual

### **Revision 1.3 (March 2024) – Hardware version 1.0**

#### **Released by ZZXIO**

The following paragraph does not apply in any country where such provisions are inconsistent with local law: THIS PUBLICATION “AS IS” WITHOUT WARRANTY OF ANY KIND, EITHER EXPRESS OR IMPLIED, INCLUDING, BUT NOT LIMITED TO, THE IMPLIED WARRANTIES OF MERCHANTABILITY OR FITNESS FOR A PARTICULAR PURPOSE. Some states do not allow disclaimer of express or implied warranties in certain transactions; therefore, this statement may not apply to you.

This publication could include technical inaccuracies or typographical errors. Changes are periodically made to the information herein; these changes will be incorporated in new editions of the publication. Improvements and/or changes in the product(s) and/or the program(s) described in this publication may change at any time. It is possible that this publication may contain reference to, or information about, products (machines and programs), programming, or services that are not announced in your country. Such references or information must not be construed to mean that anyone intends to announce such products, programming, or services in your country.

Micro Channel, Personal System/2, and PS/2 were trademarks of the International Business Machines Corporation. XTIDE Universal BIOS and associated tools are Copyright (C) 2009-2010 by Tomi Tilli, 2011-2022 by XTIDE Universal BIOS Team, and released under the GNU General Public License.

No part of this work may be reproduced or distributed in any form or by any means without prior permission in writing.

# Table of Contents

- Introduction..... 4
- Features..... 4
- Unpacking Checklist ..... 5
- Pre-Installation..... 5
- Installation..... 5
- Configuration ..... 7
- Operation ..... 8
- Connector Descriptions..... 9
- Troubleshooting..... 12

## Introduction

Thank you for your purchase of the McIDE-CF, the easiest way to add parallel advanced technology attachment (PATA) and CompactFlash (CF) devices to Micro Channel Architecture (MCA) bus systems. The McIDE-CF uses the open-source extended technology integrated drive electronics universal basic input output system (XTIDE Universal BIOS or XUB) to allow you to easily connect a variety of integrated drive electronics (IDE), enhanced integrated drive electronics (EIDE), and advanced technology attachment packet interface (ATAPI) compatible devices to your system.

Installation instructions for the adapter card and reference diskette are given below. Please take a few moments to read these instructions.

## Features

- ❖ 16-bit data transfer speeds and is fully compatible with the IBM® MCA bus interface.
- ❖ Two IDE channels support up to two CF and two IDE devices in a variety of configurations.
- ❖ Can coexist with other storage devices and adapter interface cards such as small computer serial interface (SCSI) and enhanced small diskette interface (ESDI).
- ❖ Removable and programmable 32 kilobyte erasable programmable read-only memory (EPROM) containing the XUB.
- ❖ Onboard light emitting diode (LED) that illuminates during data transfer. The system hard diskette indicator lamp (if equipped) will also illuminate during data transfer.
- ❖ AMP power connector providing +12 volts, +5 volts, and ground.
- ❖ Configurable channel interrupt request (none, IRQ 10, IRQ 11, IRQ 14, or IRQ 15).
- ❖ A modified version of the XUB to support PS/2 systems. (Do not flash a version of the XUB to the EPROM that has not been modified to support the McIDE-CF adapter.)
- ❖ Virtual serial floppy diskette drive support.
- ❖ Support for two McIDE/McIDE-CF adapters supporting up to eight devices.
- ❖ Support for two CompactFlash storage devices

## Unpacking Checklist

- McIDE-CF adapter
- This user manual (optional)
- Reference diskette with the option description file (@71f1.adf), XTIDE serial drive utility (serdrive.exe), and CD-ROM driver (gscdrom.sys) (optional)
- AMP power connector(s) (optional)

## Pre-Installation

In order to configure your McIDE-CF adapter you will need a working copy of your reference diskette with a copy of the McIDE-CF option description file. To create an updated diskette, insert the reference diskette for your system and boot the system. At the main menu, select option 5 (COPY AN OPTION DISKETTE). You will be prompted to insert your option diskette. Proceed by following these steps:

1. Remove the working copy reference diskette.
2. Insert your McIDE-CF option diskette containing the @71f1.adf file.
3. Press any key to continue.
4. You will be prompted to re-insert your reference diskette. Remove the option diskette and insert the reference diskette.
5. Press the `enter` key.

You now have an updated reference diskette that will support the installation of the McIDE-CF.

## Installation

Before proceeding with the installation, make sure that you have turned off all power to your computer and any attachments. Remove all power cords from your equipment before proceeding any further! Remove the cover from your system to allow access to the internal components and expansion slots.

Adapter cards, like all computer equipment, can be severely damaged by static electricity. Be sure that you are properly grounded before opening your computer case or touching the adapter. It is

recommended that you wear an anti-static strap when installing any computer component. If an anti-static strap is unavailable, discharge yourself of any static electricity build-up by touching a large, grounded metal surface for several seconds. Also, be careful to handle the adapter by its edges and not the gold contacts.

If installing dual MclDE adapters, remove the EPROM from the second card; only one EPROM is required.

### Removing your existing hard drive

If you are not replacing your existing hard diskette with an IDE drive(s) then proceed to the next section. Remove your existing drive(s) from the system. The hard drive removal procedure differs depending on the type and model of your system. If you have difficulties removing your existing drive have your dealer perform the installation. The existing fixed diskette controller card can also be removed from the system if it will no longer be used.

### Inserting the adapter

Select an unoccupied expansion slot and loosen the thumbscrew on the back. Pull out and remove the blank filler plate (if present) that was held in place with the thumbscrew. Insert the MclDE-CF adapter carefully into the system bus, making sure that the board is correctly positioned and held in the card guide. Press the card firmly into the bus connector and secure the board with the thumbscrew (if present).

### Connecting the interface cable

If installed an IDE device, connect one end of the 40 pin IDE cable to connector `Channel B` on the MclDE adapter. Make sure that pin 1 is aligned properly (refer to the board layout diagram in figure 1).

### Connecting the power cable

High amperage devices should be powered directly from the power supply. For systems without available connectors, a 4-pin AMP connector is available. To use, simply plug one end of the connector to the card and the other to the drive.

### Installed an internal CF card

If installing an internal CF card, install it now.

After completing the hardware installation replace all covers, attachments, and cords to your system unit. You are now ready to configure the adapter.

## Configuration

Insert the working copy of the reference diskette into drive A: and turn on the power to the system. When the system boots you should see error 165 displayed on your screen. This indicates that the computer has recognized the presence of your newly installed McIDE-CF adapter but that it has not yet been configured. Press *enter* to continue. You should see the following message: "Automatically configure the System? (Y/N)". Press Y to begin the configuration.

### Automatic configuration

Running automatic configuration will command the system to detect all installed adapters. Once automatic configuration runs, the system will typically reboot. Reboot the system and then continue to the next section.

### Selecting the option ROM type and address

When running the system configuration utility you have the ability to change the parameters of the McIDE-CF adapter. Within the main menu of the system configuration utility, select option 2, *set configuration*, press *enter*, and select option 2 again, *change configuration*, and press *enter*.

The included high-capacity option ROM contains 16 kilobytes of code. In the McIDE-CF section, select an available address base for the ROM. You can see available and used address spaces by booting from the reference diskette and selecting *Option ROM Type and Base*.

### Selecting the channel

Each IDE channel can be set as *primary*, *secondary*, *tertiary*, *quaternary*, or *disabled*. The addresses are as follows: *primary* - 1F0h; *secondary* - 170h; *tertiary* - 1E8h; *quaternary* - 168h; and *disabled* - none. There can only be one *primary*, *secondary*, *tertiary*, and *quaternary* channel. The setup utility will not allow you to make an invalid selection.

## Selecting the interrupt request

Interrupts are optional and not required for the operation of the card. The IRQs can be set to `none`, `IRQ 10`, `IRQ 11`, `IRQ 14`, and `IRQ 15`. Certain operating system drivers may expect `IRQ 14` assigned to channel A and `IRQ 15` assigned to channel B. Note that most operating systems do not support shared IRQs.

## Configure the CompactFlash slots

Channel A controls both CompactFlash slots. Either CompactFlash slot can be the master. Under `CompactFlashMaster` select `Internal` or `External`. Only one card can be configured as master, and only one as slave. The system will not allow you to save an invalid configuration.

## XTIDE Universal BIOS configuration

More information about the XTIDE Universal BIOS, including advanced configuration options, is available on the world wide web at <https://www.xtideuniversalbios.org/>.

## Operation

During POST, the XUB will scan all channels. If the McIDE-CF is configured via the reference diskette with only one channel enabled, the BIOS will report that no devices were found on the disabled channel(s), even if devices are present.

While the XUB is identifying drives you may press any drive letter (e.g., A, C, or D) to boot from that drive. You can also press `F2` to bring up a boot menu, `F6` to scan for a virtual serial floppy diskette drive, or `F8` to boot from ROM.

## Virtual serial floppy drive

The virtual serial floppy allows the computer to boot any floppy diskette (e.g., a reference diskette), even when a floppy drive is not connected to the computer. The virtual serial floppy drive requires two computers, one that receives the data, and one that hosts the virtual floppy drive. The two computers are connected via a null modem cable.



Once the two computers are connected via serial cable, on the sending computer open the serdrive.exe utility and specify the diskette image to use (e.g., c:\serdrive reference\_disk.ima). Boot the receiving computer, pressing F6 when XUB is detecting the attached drives. If you wish to boot from the virtual floppy, press F2. To exit the serial drive utility, press `ctrl+c` on the host computer. You can optionally specify another diskette to attach.

Details regarding additional options are available online.

## ATAPI drives

The XUB does not provide native support for ATAPI devices, but limited use is possible. Optical drives can be used with the appropriate driver. Note that certain software (including most optical diskette drive drivers, such as `gsdrom.sys`) expect to find the primary IDE channel at address 1F0h and IRQ 14 and the secondary IDE channel at address 170h and IRQ 15. Ensure that the MclDE configuration matches the expected configuration of the driver.

## Connector Descriptions

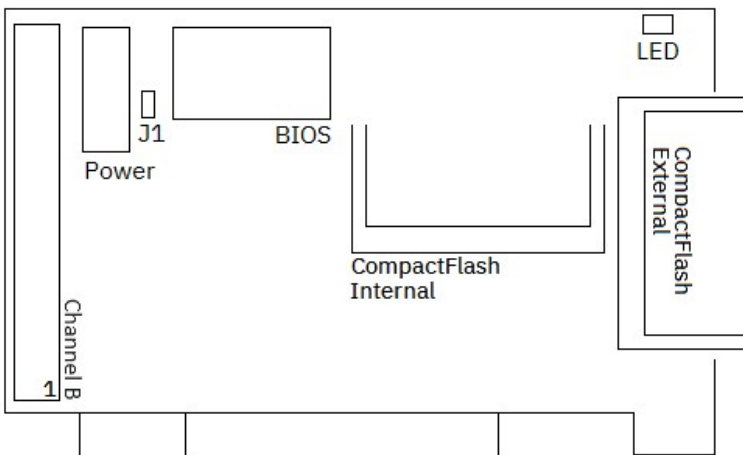

Figure 1 – Adapter layout

## BIOS

The XUB is stored on a standard 28-pin EPROM. The EPROM can exist in any compatible socket. The McIDE-CF adapter can read a maximum of 16KiB of data from an EPROM. Be sure to note the alignment key in the EPROM when reinstalling into the socket. Only one XUB should be installed per system.

## Power

+5 and +12 volt power is available on the adapter. High amperage devices should not be connected via this connector.

## Channel A/B

Pin	Signal	Pin	Signal	Pin	Signal	Pin	Signal
1	Reset	2	Ground	21	Ground	22	Ground
3	HD7	4	HD8	23	-HIOW	24	Ground
5	HD6	6	HD9	25	-HIOR	26	Ground
7	HD5	8	HD10	27	IOCHRDY	28	HALE
9	HD4	10	HD11	29	Unused	30	Ground
11	HD3	12	HD12	31	IRQBUS	32	-IOCS16
13	HD2	14	HD13	33	HAI	34	Unused
15	HD1	16	HD14	35	HAO	36	HA2
17	HD0	18	HD15	37	-HCSO	38	-HCSI
19	Ground	20	Key	39	SLV ACT	40	Ground

Figure 2 - AT Bus Hard Diskette Drive Interface

Each channel will support up to two devices. Be sure the first device (at the end of the cable) is set to master (or cable select) and the second (at the middle of the cable) device is set to slave (or cable select). Some devices, such as SD to IDE adapters, can only be used as the master device. These devices can co-exist with a slave device on the same ribbon cable.

## JP1

JP1 is not used in normal operation. When the adapter is not configured, connecting this jumper will force the ROM to respond at address 0xC000, which would cause the machine to boot from the BIOS even without having configured it. You could then use the virtual serial floppy to boot a reference disk, allowing you to configure a machine with a missing or defective floppy drive.

## LED

All MCA bus PS/2 systems are equipped with hard diskette drive access indicator LED. This LED can be controlled by the adapter. An LED is also included on the adapter.

## Troubleshooting

Please review the following pages for troubleshooting tips.

### Boot diskette or operating system does not recognize optical drives

Ensure that the correct port and IRQ are set and a driver is installed that searches for the port and IRQ the optical drive is installed on.

### Cannot boot from CD/DVD-ROM

The XTIDE Universal BIOS does not support booting from an optical drive. Use a floppy diskette with optical drive support.

### CompactFlash card cannot be partitioned or formatted

While certain CompactFlash cards are not bootable, another possibility is that incompatible data exists on the card. One way to remove this data is via diskpart on Windows Vista and later:

- Run `diskpart`
- To view available disks, type `list disk`
- Select the CF card with the `select disk #` command (replace # with the number of your CF drive)
- Type `clean` (this will erase all data on the selected disk)
- The drive is now ready. Optionally, type `create partition primary align=1024, then active, then format fs=fat16 quick` or `format fs=fat32 quick`, and finally `exit` to quit.

### Direct memory access (DMA) is not available

This feature is not supported.

### Drive on PATA to SATA adapter not working properly

PATA to SATA adapters are not supported. The system can become unresponsive with a PATA to SATA adapter installed in certain configurations.

### Errors on boot (including 19990021, 00026900, 19990303)

Certain PS/2 models with on-board SCSI expect to see a SCSI hard drive on SCSI ID 6. When a drive is not present at this ID, during power on the

computer will do a memory check, display an error code, reboot, perform another memory check, display additional error code(s), and then proceed booting as normal. This is expected behavior.

### Extended memory is not available

Many memory expansion adapters store data on the boot drive. After installing your new drive, create and format a primary partition and then rerun automatic configuration using your reference disk. After running automatic configuration verify the MclDE-CF parameters (ROM type and address, along with the IRQ (if any) of each channel) and configure the memory expansion adapter card. The memory on expansion adapters is only available when booting from a hard drive, as the code to enable the expansion adapter is skipped when the XUB boots from a floppy drive.

There are several workarounds if you cannot install an operating system due to insufficient memory while booting from the floppy drive. Many operating systems can disable the memory check during installation via a switch. Many also support the installation of the OS via the hard drive. Another option is to begin the installation on another system and then connect the drive to the PC.

### HDD LED does not illuminate

The HDD activity indicator LED may not illuminate when third party hard disk controller drivers are installed for the adapter (e.g., the Windows® 95 Standard IDE/ESDI Hard Diskette Controller). Using a compatible driver (e.g., IBM MCA Integrated Fixed Diskette and Controller) will correct this issue.

### Keyboard unresponsive after booting OS

If the keyboard does not respond to input after installation of an operating system, boot the system via a floppy disk with a release of DOS that supports the `fdisk /mbr` command (e.g., a Windows® 98 boot disk). Run the command and then reboot the system.

## McIDE-CF is not detected, error 165 after running system configuration

Certain device configurations can cause the McIDE-CF adapter to become unresponsive or not be detected by the system. Disconnect all drives and add them one at a time to determine the device that is causing the issue. Also verify that the EPROM is seated in the ROM socket.

## System does not boot the XTIDE Universal BIOS

Remove all cables from the card, does this resolve this issue? If so, try a replacement IDE cable. Extra long cables outside the IDE specification can cause detection issues. If this does not resolve the issue, remove all devices and add one device back at a time to isolate the drive causing the issue.

## System does not recognize more than two hard drives

Ensure the second channel is active. Also, DOS versions 4.xx do not recognize more than two drives. This is due to a bug in these versions of DOS that limits the number of hard drives to two. This problem can be resolved by using DOS 3.3 or 5.0 or later.

## XTIDE Universal BIOS does not recognize certain devices

The XTIDE Universal BIOS does not support ATAPI devices, but many of these devices are visible to the system if the appropriate driver is successfully loaded.

Notes:

Notes:

For further information, visit us on the World Wide Web at [zzxio.com](http://zzxio.com) or contact us at [support@zzxio.com](mailto:support@zzxio.com).

**zzxiö**